

P958 One 26W-32W Triple Tube Lamp
P959 One 42W Triple Tube Lamp

Lens Wall Washers
7 1/4" Conoid Apertures

Optics and Applications

The optical systems utilize triple tube lamps, full circle kicker reflectors and proprietary borosilicate glass prismatic spread lenses to provide even distribution without hot spots or striations. Parabolic cones control spill light and prevent objectionable brightness. Use to light walls, murals, bookcases, paintings, textured surfaces, etc.

Design Features

Sturdy steel housings protect the optical systems and allow easy access to all components. The cone and lens assemblies are held tightly to the ceiling with constant torsion spring pressure. Vented air flow design assures cool fixture temperature for optimal lamp performance. Maximum ceiling thickness 1 1/2". Ballast and lamp service from below.

Finish

Specular clear Alzak cones are standard. Optional colors and Softglow® finishes are available. Housings and structural parts are phosphated for corrosion resistance before being painted optical matte black for control of stray light leaks.

Ballasts

Fully electronic, microprocessor controlled with variable starting current for inrush protection to assure rated lamp life. Input voltage ranges from 120V through 277V. Operates multiple wattage interchangeably. Power factor .98, starting temperature 0° F (-18° C), THD < 10%. Pre-heat start < 1.0 second. End of lamp life protection. Rated for > 50,000 starts.

General

Fixtures are pre-wired, UL and C-UL listed for eight wire 75°C branch circuit wiring. Union made IBEW. Luminaire Efficiency Ratings (LER) do not apply to wall washers.

Accessories

- G Gold cone.
- H Mocha cone.
- P Graphite cone.
- T Titanium cone.
- W Wheat cone.
- Y Pewter cone.
- Z Bronze cone.
- S Softglow® finishes: add S before color letters. e.g. SW for Softglow® wheat cone, SC for Softglow® clear cone.
- R2 26" support rails.
- R5 52" support rails.
- WT White trim flange.
- WHT White complete trim.
- V347 347 volt ballast.
- F Fuse.
- DM Dimming ballast. Specify watts and volts.
- EM Emergency power includes integral charger light and test switch visible through aperture. Single lamp operation for 90 minutes. Specify volts.
- WRL Wattage restriction label, specify wattage.

Dimensions and Lamps

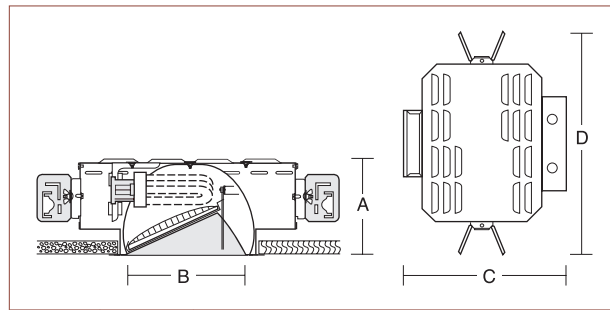

Number	A Depth	B Aperture	C Width	D Length	Lamp
P958	6 1/4" 159mm	7 1/4" 184mm	13 1/2" 343mm	19" 483mm	26-32W Triple Tube
P959	6 1/4" 159mm	7 1/4" 184mm	13 1/2" 343mm	19" 483mm	42W Triple Tube

Matching Units

- Medium narrow beam downlights [Page P53](#)
- Medium wide beam downlights [Page P55](#)
- Cross baffled downlights [Page P24](#)
- Slope ceiling downlight [Page P54](#)
- Surface mount [Page P41](#)

** Click for link to pages in blue.

P66 P958 P959

Candlepower Distribution Curves

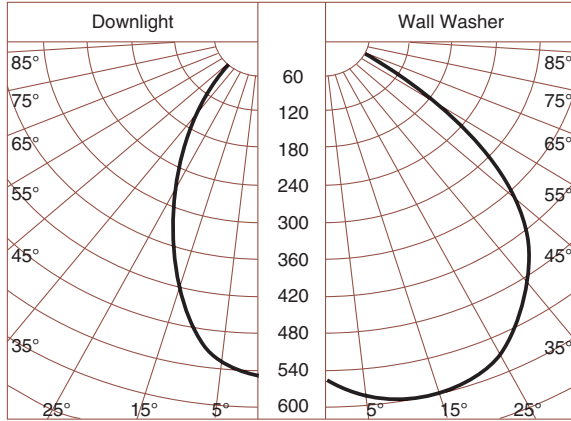

P958 One 32W Philips Triple Tube

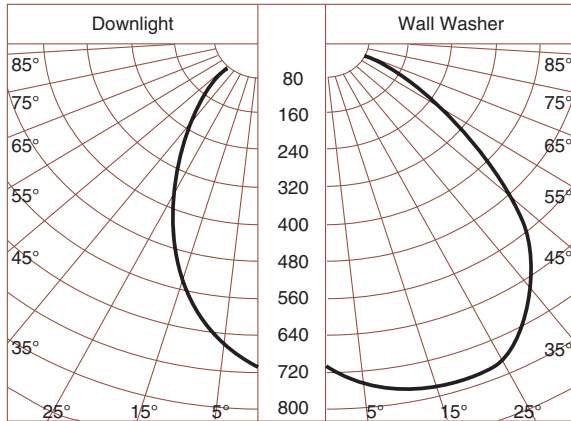

P959 One 42W Philips Triple Tube

Multiple Units Footcandles

From Ceiling	2' from wall		3' from wall				4' from wall					
	2' Centers		3' Centers		3' Centers		4' Centers		4' Centers		6' Centers	
	CL	Mid	CL	Mid	CL	Mid	CL	Mid	CL	Mid	CL	Mid
1'	30	30	23	18	9	8	7	6	4	4	3	2
2'	58	57	41	37	19	19	15	14	8	7	6	4
3'	47	47	32	31	26	26	20	20	12	12	9	7
4'	33	33	22	22	24	23	18	18	15	15	11	9
5'	23	23	16	15	19	18	14	14	14	14	10	9
6'	17	17	11	11	15	14	11	11	12	12	8	8
7'	13	13	8	8	12	11	9	9	10	10	7	6
8'	10	10	6	6	9	9	7	7	8	8	6	5
10'	6	6	4	4	6	5	4	4	6	5	4	3
12'	4	4	3	3	4	4	3	3	4	4	3	2

P958 One 32W Philips Triple Tube
P958 One 32W Osram Sylvania Triple Tube

From Ceiling	2' from wall		3' from wall				4' from wall					
	2' Centers		3' Centers		3' Centers		4' Centers		4' Centers		6' Centers	
	CL	Mid	CL	Mid	CL	Mid	CL	Mid	CL	Mid	CL	Mid
1'	39	36	30	23	12	11	10	7	5	5	4	3
2'	72	69	53	45	24	23	20	16	10	9	7	5
3'	57	56	39	37	33	32	26	22	16	15	12	9
4'	40	39	27	26	29	28	22	20	19	18	14	11
5'	28	28	19	18	23	22	17	16	17	17	12	11
6'	20	20	14	13	18	17	13	12	15	14	10	10
7'	15	15	10	10	14	14	10	9	12	12	8	8
8'	12	12	8	7	11	11	8	7	10	10	7	7
10'	7	7	5	5	7	7	5	5	7	7	5	5
12'	5	5	3	3	5	4	3	3	5	5	3	3

P959 One 42W Philips Triple Tube
P959 One 42W Osram Sylvania Triple Tube

Notes

- 1 Data by IES methods. Compact fluorescent data vary due to lamp lumen differences, power input, burning position, ambient temperature and ballast characteristics. A modification factor should be applied.
- 2 Above data measure output of the wall washers only. No contribution from adjacent downlights or ceiling, floor or wall reflectances is included. Total illumination on the wall will increase with the contribution from other sources.
- 3 Data are cosine corrected to the plane of the wall. Uncorrected data are substantially higher and depend upon the angle of incidence to the wall which varies with the mounting distance from the wall.
- 4 Kurt Versen wall washers are designed to minimize hard shadow lines at the ceiling. Light intensity increases gradually to the maximum area, just above eye level. The field is uniform, devoid of hot spots, striations and spikes.
- 5 If colored cones are required, only the downlight cone will be tinted. The kicker reflector is always clear Alzak for maximum output and true color rendition.
- 6 Specular cone multipliers: For downlight and brightness data only: Gold x .92, Wheat x .89, Pewter x .81, Mocha x .79, Graphite x .76, Titanium x .76, Bronze x .73.
- 7 Softglow® cone multipliers: For downlight and brightness data only: Clear x .98, Gold x .90, Wheat x .89, Mocha x .77, Pewter x .74, Graphite x .72, Titanium x .72, Bronze x .70.
- 8 Brightness data from the Average Luminance Method are inaccurate for small aperture downlights. They are theoretical calculations derived for large surfaces like troffers. For a complete discussion refer to section Z brochure Z1.

Brightness

Number	Lamps	85°	75°	65°	55°	45°
P958	One 32W Osram Triple Tube	2	3	228	1493	4088
	One 32W Philips Triple Tube	2	3	251	1541	4153
P959	One 42W Osram Triple Tube	2	5	237	1926	4484
	One 42W Philips Triple Tube	2	3	312	1854	4391

Data in footlamberts. Photometer readings, Maximum Brightness Method. See note 8.