

Dimensions and Lamps

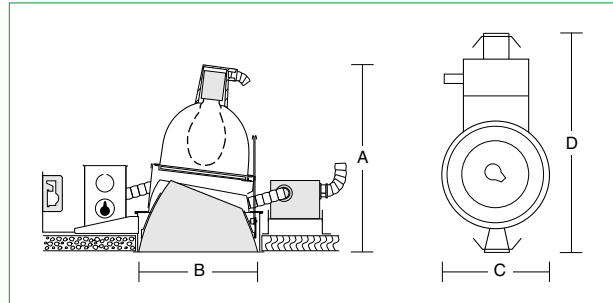

Number	A Depth	B Aperture	C Width	D Length	Lamps*
R7381	19 1/2" 495mm	11 1/2" 292mm	13" 330mm	20" 508mm	175W MH E-28 or BT-28
R7382	19 1/2" 495mm	11 1/2" 292mm	13" 330mm	20" 508mm	250W MH E-28 or BT-28

*Clear lamps for narrow distribution. For wider distribution use coated lamps.

R7381 DISCONTINUED R25

R7382 DISCONTINUED

Contact Factory

Narrow Distribution Directionals
175-250W Metal Halide Lamps
11 1/2" Conoid Apertures

Optics and Applications

Primary reflectors produce narrow controlled beams for high ceiling applications. Parabolic shielding cones control brightness. Clear lamps produce the tightest pattern, coated lamps somewhat wider. Use in atriums, malls, convention centers, transportation terminals etc.

Design Features

These units are designed for sloped ceilings or for directional lighting in flat ceilings. Angulation to 30° with full circle rotation and positive locking in all positions. For top aiming, consult factory. Cast heat sinks assure cool operation. Maximum ceiling thickness on both models is 2". Relamp from above or below.

Finish

Specular clear Alzak cones are standard. Optional colors and Softglow® finishes are available. Structural parts are painted optical matte black to suppress stray light leaks.

Ballasts

CWA, encased and potted magnetic, high power factor with dual taps for 120V or 277V. Shipped for 277V, field conversion to 120V with a simple splice. Thermally protected with automatic reset. Operating temperature range from -20° F to 130° F. Mounted on a saddle plate with 4' of flex. Removable through the aperture for service.

General

Fixtures are pre-wired and thermally protected, UL and C-UL listed for eight wire 75°C branch circuit wiring. Union made IBEW. Luminaire Efficiency Ratings (LER) do not apply to directionals.

Accessories

- R2 26" support rails.
- R5 52" support rails.
- B Specular black cone.
- G Specular gold cone.
- H Specular mocha cone.
- P Specular graphite cone.
- S Softglow® finishes: add S before color letters. e.g. SW for Softglow® wheat cone, SC for Softglow® clear cone.
- EC Emergency circuit with mini-can socket and leads.
- AO Instant restrike Auto-On system. Maximum aux. 100W T-4.
- OP Open construction, no lamp shield. Not available with EC or AO accessories.
- V347 347 volt ballast, contact the factory.
- PUL Pulse start ballast, contact the factory.
- F Ballast fuse.
- WT White trim flange.
- T Specular titanium cone.
- W Specular wheat cone.
- Y Specular pewter cone.
- Z Specular bronze cone.

Matching Units

- 400W directional Page R26
- Straight downlights Pages R22, R24
- Surface cylinders Pages S1, S2, S3

R25 R7381 R7382

Footcandle Values at Nadir

Distance	20'						30'						40'						50'					
	Nadir	5°		10°		Nadir	5°		10°		Nadir	5°		10°		Nadir	5°		10°					
Lamps	FC	FC	Diam	FC	Diam	FC	FC	Diam	FC	Diam	FC	FC	Diam	FC	Diam	FC	FC	Diam	FC	Diam				
R7381 175W E-28 Clear	129	74	3'	31	7'	57	33	5'	14	11'	32	19	7'	8	14'	21	12	9'	5	18'				
R7382 250W E-28 Clear	189	109	3'	45	7'	84	48	5'	20	11'	47	27	7'	11	14'	30	17	9'	7	18'				

Distance	15'						20'						30'						40'					
	Nadir	10°		15°		Nadir	10°		15°		Nadir	10°		15°		Nadir	10°		15°					
Lamps	FC	FC	Diam	FC	Diam	FC	FC	Diam	FC	Diam	FC	FC	Diam	FC	Diam	FC	FC	Diam	FC	Diam				
R7381 175W E-28 Coated	46	36	5'	29	8'	26	20	7'	16	11'	11	9	11'	7	16'	6	5	14'	4	21'				
R7382 250W E-28 Coated	62	49	5'	40	8'	35	28	7'	22	11'	15	12	11'	10	16'	9	7	14'	6	21'				

See note 5.

Candlepower Distribution

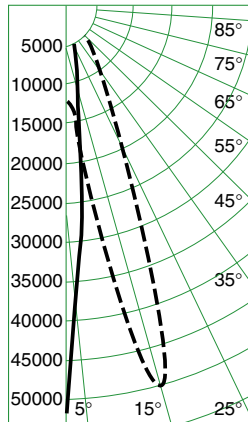

R7381 175W E-28 Clear
Eff. 58% S/M .21

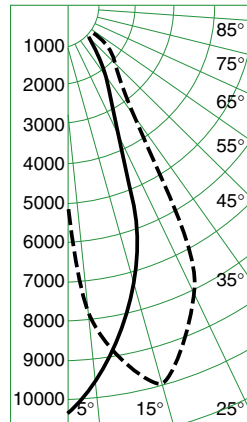

R7381 175W E-28 Coated
Eff. 47% S/M .68

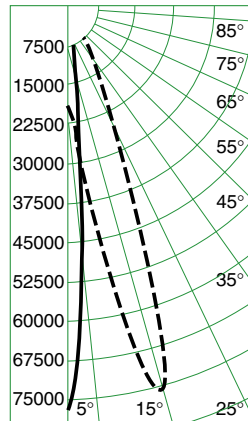

R7382 250W E-28 Clear
Eff. 58% S/M .21

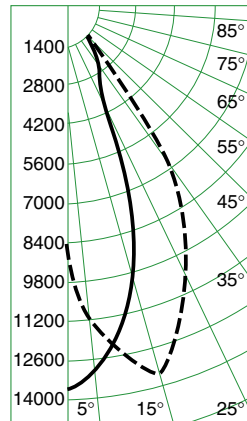

R7382 250W E-28 Coated
Eff. 44% S/M .68

Candelas

	Clear	Coated
o	14000*	14000*
0	51712	10257
5	30003	9575
10	12876	8538
15	8979	7293
20	5108	5692
25	3142	3784
30	2618	2523
35	2153	2030
40	1000	1713
45	675	783
50	267	201
55	44	18
60	3	0
65	0	0
70	0	0
75	0	0
80	0	0
85	0	0
90	0	0

o Vertical Angles
* Initial Lamp Lumens

	Clear	Coated
o	20500*	20500*
0	75578	13948
5	44030	13022
10	18855	11612
15	11791	9918
20	7577	7740
25	4836	5145
30	4347	3431
35	3091	2761
40	1464	2222
45	947	1060
50	465	270
55	84	27
60	4	0
65	0	0
70	0	0
75	0	0
80	0	0
85	0	0
90	0	0

o Vertical Angles
* Initial Lamp Lumens

Brightness

Number	Lamps	85°	75°	65°	55°	45°
R7381	175W E-28 Clear	17	35	73	165	2976
	175W E-28 Coated	15	27	50	103	2167

Number	Lamps	85°	75°	65°	55°	45°
R7382	250W E-28 Clear	25	50	105	229	4292
	250W E-28 Coated	20	36	67	138	2935

Data in footlamberts. Photometer readings, Maximum Brightness Method. Data collected with lamps tilted 15°. See note 7.

Notes

- Data derived with clear specular cones.
- Colored cone multipliers, coated lamps: Gold x .95, Wheat x .94, Pewter x .91, Mocha x .90, Graphite x .90, Titanium x .90, Bronze x .88, Black x .72.
- Colored cone multipliers, clear lamps: Gold x .98, Wheat x .98, Pewter x .96, Mocha x .95, Graphite x .95, Titanium x .95, Bronze x .94, Black x .80.
- Candlepower distribution curves: solid lines show horizontal distribution at nadir, dotted lines show horizontal distribution at 15° lamp tilt
- Degree headings are measured from one side of nadir. Diameter data includes both sides. Therefore the 5° column describes a total 10° pattern diameter above the floor. Footcandle values are at the diameter edge. Values are determined with lamp tilt at 0°. Angulation changes all data.
- Fixtures accept E-28 or BT-28 lamps.
- Brightness data from the Average Luminance Method are inaccurate for downlights. They are theoretical calculations for large surfaces such as troffer lenses. We recommend the stricter standard of Maximum Brightness Method point data from direct photometer readings. They approximate what the human eye perceives when evaluating glare. For more information refer to Z section brochure Z1.